

SE-1OS-3042BC

■Features

- High Luminous Output
- 10mm Standard Directivity
- Superior Weather-resistance
- UV Resistant Epoxy
- Water Clear Type
- Chip Materials : InGaN

■Applications

- Traffic Signal Lamp
- Automotive Lighting
- Commercial Outdoor Signs
- Other Lighting

■Outline Dimension

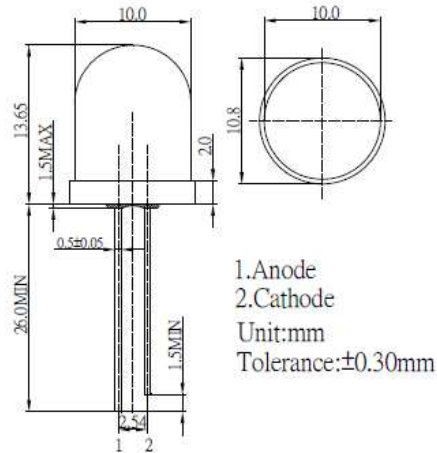

■Absolute Maximum Rating

(Ta=25°C)

| Item | Symbol | Value | Unit |
|----------------------------|-----------|------------|------|
| DC Forward Current | I_F | 30 | mA |
| Pulse Forward Current* | I_{FP} | 100 | mA |
| Reverse Voltage | V_R | 5 | V |
| Power Dissipation | P_D | 108 | mW |
| Operating Temperature | T_{opr} | -30 ~ +85 | °C |
| Storage Temperature | T_{stg} | -40 ~ +100 | °C |
| Lead Soldering Temperature | T_{sol} | 260°C/5sec | - |

*Pulse width Max 10ms Duty ratio max 1/10

■Directivity

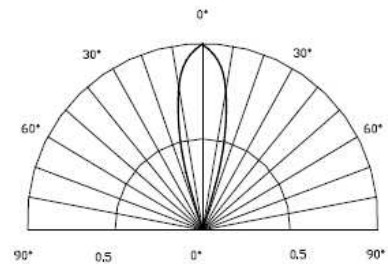

■Electrical -Optical Characteristics

(Ta=25°C)

| Item | Symbol | Condition | Min. | Typ. | Max. | Unit |
|--------------------|-----------------|------------|------|------|------|------|
| DC Forward Voltage | V_F | $I_F=20mA$ | 2.9 | 3.1 | 3.6 | V |
| DC Reverse Current | I_R | $V_R=5V$ | - | - | 10 | μA |
| Dom. Wavelength | λ_D | $I_F=20mA$ | 465 | 470 | 475 | nm |
| Luminous Intensity | I_v | $I_F=20mA$ | 3000 | 4200 | 5800 | mcd |
| 50% Power Angle | $2\theta_{1/2}$ | $I_F=20mA$ | - | 30 | - | deg |

*1 Tolerance of dominant wavelength is ±1nm

*2 Tolerance of luminous intensity is ±15%

