

SE-5OS-1060GD-5V

■ Features

- High Luminous LEDs
- 5mm Round Standard Directivity
- Superior Weather-resistance
- UV Resistant Epoxy
- Integral Current Limiting Resistor
- TTL Compatible (Requires No External Current Limiter With 5 Volt Supply)
- Cost Effective (Saves Space and Resistor Cost)
- Color Diffused Type

■ Applications

- Status Indicators
- Other Lighting

■ Outline Dimension

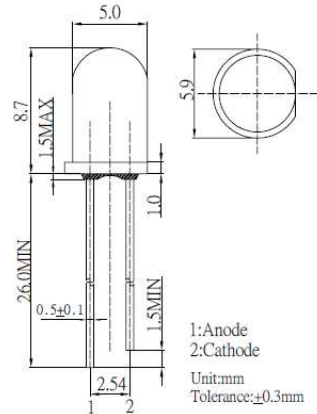

■ Absolute Maximum Rating

(Ta=25°C)

Item	Symbol	Value	Unit
DC Forward Voltage	V_F	7.5	V
Reverse Voltage	V_R	5	V
Power Dissipation	P_D	150	mW
Operating Temperature	T_{opr}	-30 ~ +85	°C
Storage Temperature	T_{stg}	-40 ~ +100	°C
Lead Soldering Temperature	T_{sol}	260°C/5sec	-

■ Directivity

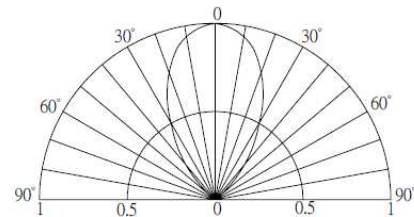

■ Electrical -Optical Characteristics

(Ta=25°C)

Item	Symbol	Condition	Min.	Typ.	Max.	Unit
DC Forward Current	I_F	$V_F = 5V$	-	12	20	mA
DC Reverse Current	I_R	$V_R = 5V$	-	-	10	μA
Domi. Wavelength*	λ_D	$V_F = 5V$	565	570	575	nm
Luminous Intensity*	I_v	$V_F = 5V$	68	100	-	mcad
50% Power Angle	$2\theta_{1/2}$	$V_F = 5V$	-	60	-	deg

*1 Tolerance of dominant wavelength is $\pm 1nm$
 *2 Tolerance of luminous intensity is $\pm 15\%$

AlGaInP and Si Resistor LED

TYPICAL ELECTRICAL/OPTICAL CHARACTERISTIC CURVES

